

# ELECTRONIC DENSIMETER MDS-300 & MDS-3000

## INSTRUCTION MANUAL

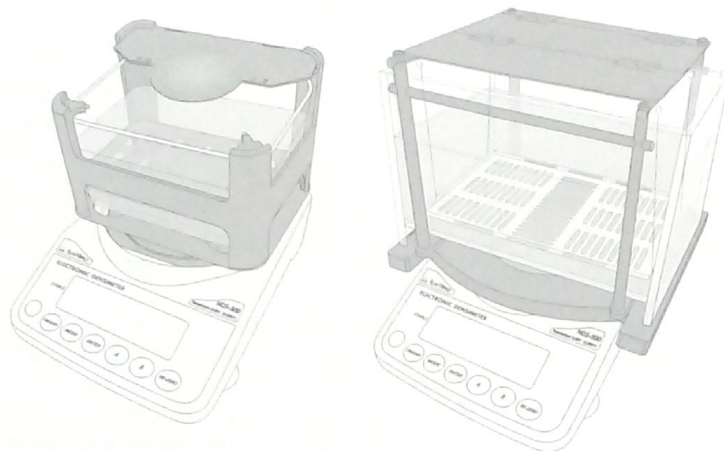

**MDS-300 & MDS-3000** which are combined the high-precision electronic balance, installed original software with the container for measuring the specific gravity of solid, liquid and powder accurately in easy and speedy way. These machines adopt Archimedes' principle and conform to various standards.

## MDS-300 & MDS-3000 PRECAUTIONS FOR USE

### 1. Samples that can be measured

- ① Solid such as Rubber, Plastic, Glass, Metal and Ceramic .
- ② Special shape of solid such as Pellet, Fiber, Paper and Film.
- ③ Sample which floats in water.
- ④ Sample which has water absorbency.
- ⑤ Liquid of low viscosity.
- ⑥ Some kinds of powder.

### 2. Accurate results cannot be achieved on the following occasions.

- ① Liquid of high viscosity.      ② Solid which melts into solution for measurement.

### 3. Be careful about the following matters to prevent failure and electric leakage.

- ① Do not spill water onto the machine body and spare parts.
- ② Do not spill water onto the machine body and spare parts when putting a sample in and out.
- ③ Refrain from placing the body on a tremulous location, which may spill water.
- ④ Empty the Water Tank and pull off the plug when not used.
- ⑤ MDS-300 can measure up to 300g, MDS-3000 can measure up to 3kg. Do not put an object over these weights.

### 4. Be careful about the following matters in order to measure accurately.

- ① Set up spare parts correctly.
- ② Install in a stable place avoiding vibration and shock.
- ③ Use the Airtight Wind Shield attached to MDS-300.  It is the optional parts for MDS-3000.
- ④ Measuring table should be solid and free from vibration, drafts and as level as possible.

### 5. MDS-300:

The Water Tank is made from Styrene resin and the Sensor & the Support are made from ABS resin.

### MDS-3000:

The Water Tank is made from PET resin and the Measuring Tray unit is made from Stainless.

Do not use such solution as to erode them.

Do not leave as it is after using other liquid except for water.

### 6. This machine can calculate the specific gravity based on the weight of sample.

Please calibrate periodically by using the 200g calibration weight for MDS-300 and 2kg calibration weight (option) for MDS-3000 in order to measure accurately.

# CONTENTS

■ PRECAUTIONS FOR USE .....	TOP PAGE
■ NAME & FUNCTION .....	1
■ HOW TO SET UP MDS-300 AND MDS-3000 .....	2
■ WARMING UP .....	3
■ CALIBRATION .....	3
■ INITIAL SETTING .....	5
■ HOW TO SET UP OTHERS	
1. COMPENSATE WATER TEMPERATURE .....	5
2. INPUT THE SPECIFIC GRAVITY OF SOLUTION .....	6
■ SOLID DENSITY MODE	
1. STANDARD MEASUREMENT .....	7
2. FLOATING SAMPLE MEASUREMENT .....	9
3. ABSORBENT SAMPLE MEASUREMENT .....	9
4. PELLET AND POWDER MEASUREMENT .....	10
■ LIQUID DENSITY MODE	
1. ROOM TEMPERATURE LIQUID DENSITY .....	11
2. OPTIONAL COMPENSATE TEMPERATURE LIQUID DENSITY .....	13
■ COMPARATOR FUNCTION .....	14
■ DATA OUTPUT .....	15
■ INITIAL SETTING LIST .....	16
■ ERROR CODE / SPECIFICATION .....	BACK PAGE



# NAME & FUNCTION

## ACCESSORIES & COMPOSITION

See the illustrations to confirm that everything is contained.

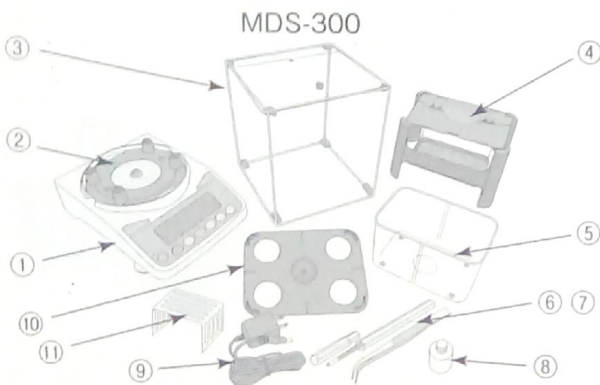

- ① MAIN BODY ② WATER TANK HOLDER  
 ③ AIRTIGHT WIND SHIELD ④ SENSOR  
 ⑤ WATER TANK ⑥ TWEEZERS ⑦ THERMOMETER  
 ⑧ 200g CALIBRATION WEIGHT ⑨ AC ADAPTOR  
 ⑩ SUPPORT ⑪ STAINLESS ANGLE

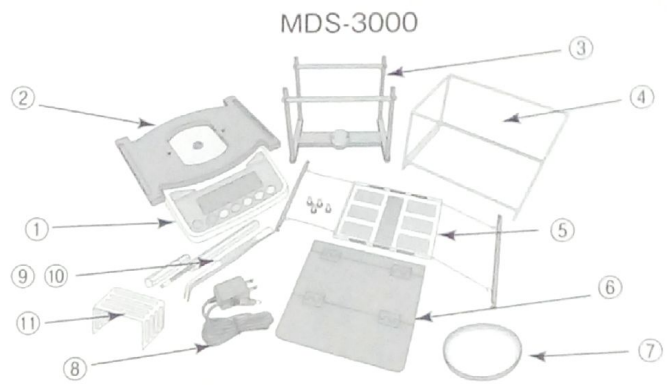

- ① MAIN BODY ② WATER TANK HOLDER  
 ③ SENSOR ATTACHMENT ④ WATER TANK  
 ⑤ MEASURING TRAY UNIT ⑥ LID  
 ⑦ DISH ⑧ AC ADAPTOR ⑨ TWEEZERS  
 ⑩ THERMOMETER ⑪ STAINLESS ANGLE

## DISPLAY

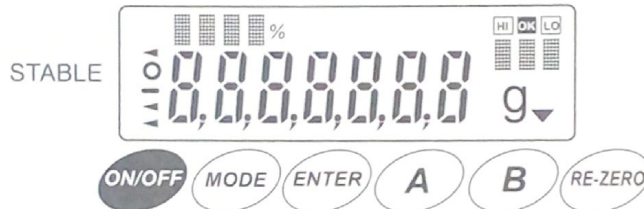

**STABLE** : Stable mark "○" appears on the upper left side when the numeric becomes stable.

### Before measurement

- g** : This shows aerial gravity(gram) or underwater gravity(gram).  
**SG(Upper left)** : Show the SOLID DENSITY MODE.  This changes for every mode.  
**g▼** : ▼ appears right of g-mark when the aerial gravity is memorized.

### After measurement

- SG(Upper right)** : Shows the specific gravity.  
**ERR(Upper right)** : Shows error of the specific gravity.  
**V(Upper right)** : Shows volume.

## SWITCH KEY

Key	When pressed	When pressed and held (for 5 seconds)
ON/OFF	To turn the display on and off	
MODE	① Before measurement: To change the PAGE of Initial Setting ② Before measurement: To change other Setting	To change Measuring Mode Solid → (Liquid) → (Optional) → Solid * ( ) can be used after changing the Initial Setting
ENTER	① Measurement: This is the main key for measuring ② Before measurement: To select the Initial Setting ③ Before measurement: To calibrate	① Before measurement: To set the temperature of water. ② Before measurement: To set the specific gravity of the liquid and the coefficient rate.
A	① Before measurement: To change present value of the Initial Setting ② Before measurement: To increase the numeric in setting a value ③ After measurement: To change the display.	① Before measurement: To select others.
B	① Before measurement: To change the CODE of the Initial Setting ② Before measurement: To decrease the numeric in setting a value ③ After measurement: To output of data	① Before measurement : To enter Calibration Mode ② During measurement: It returns to the last procedure
RE-ZERO	① To set the display to zero ② To cancel a present value in a setting mode	

# HOW TO SET UP

## ◆ CONVENIENT FUNCTION

MDS-300 can make the Lid into a half size so that it can be measured more efficient and accurate. Please use the Lid separated as following pictures for small samples.

☑ MDS-3000 can also make the Lid into a half size.



Previous Sensor



New Sensor



Remove the front part of the Lid gently.



The Lid becomes about a half size,

\*No need to open and close every time.

## MDS-300

- ① Place the Body on a stable location where is no vibration.
- ② The Body has a Spirit Level at the front left side. Twist the Adjustment Feet on the underside to level.



- ③ This Body has been equipped with the Water Tank Holder at the factory. Set up the Body and the Support following instruction.

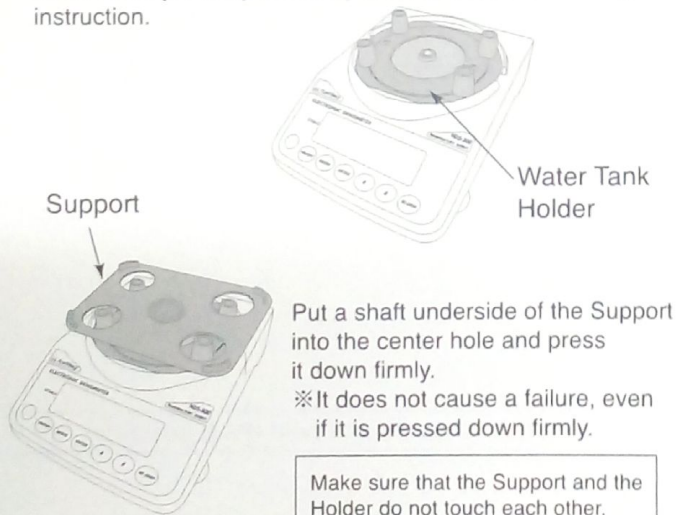

Put a shaft underside of the Support into the center hole and press it down firmly.  
※ It does not cause a failure, even if it is pressed down firmly.

Make sure that the Support and the Holder do not touch each other.

- ④ Pour water up to the inner line of the Water Tank. Fit it on the convexities of the Water Tank Holder. Put a few drops of mild detergent in the Water Tank. It will be great help to remove air bubbles.

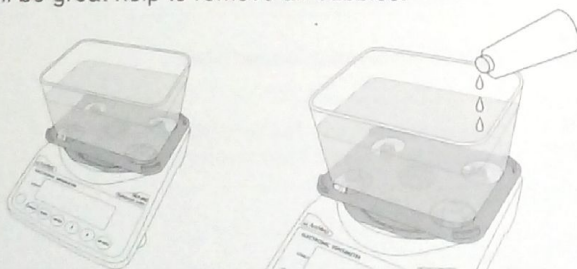

## MDS-3000

- ① Place the Body on a stable location where is no vibration.
- ② The Body has a Spirit Level at the front left side. Twist the Adjustment Feet on the underside to level.



- ③ This Body has been equipped with the Water Tank Holder at the factory. Set up the Body and the Sensor Attachment following instruction.

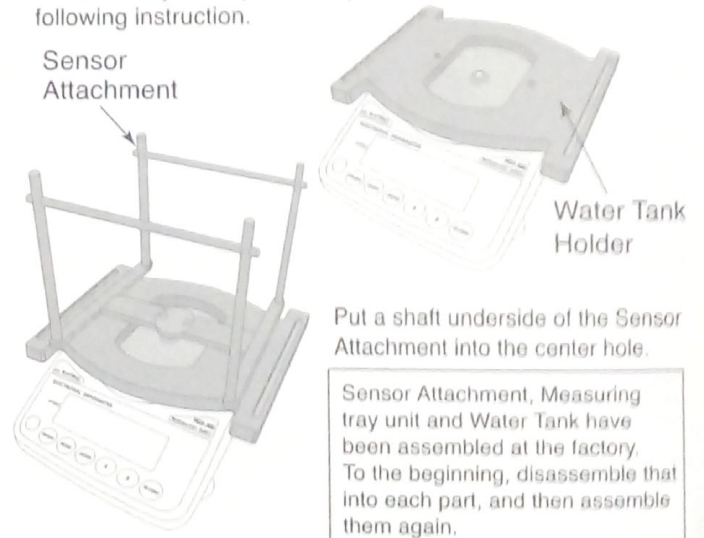

Put a shaft underside of the Sensor Attachment into the center hole.

Sensor Attachment, Measuring tray unit and Water Tank have been assembled at the factory. To the beginning, disassemble that into each part, and then assemble them again.

- ④ Pour water up to the 70% line of the Water Tank. Fit it on the 2 concavities of the Water Tank Holder. Put a few drops of mild detergent in the Water Tank. It will be great help to remove air bubbles.

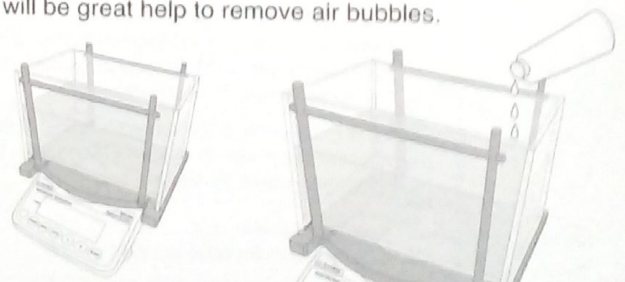



- ⑤ Put the Sensor over the Water Tank gently.  
Make sure that the bottom of the Sensor is correctly positioned on the Support. Sink the Measuring Tray into water.



- ⑥ Over the Airtight Wind Shield.  
It has finished setting. Please confirm that the AC adapter type is correct for your local voltage and receptacle type.



- ⑦ An Airtight Wind Shield could face to any direction.

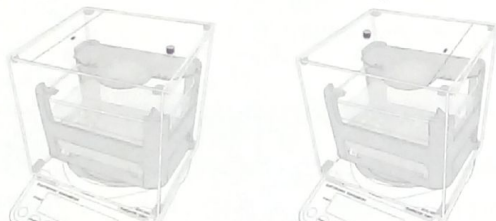

- ⑤ Equip two horizontal bars of the Measuring Tray unit at 4 vertical Sensor Attachment. At first, screw two positions of the front.

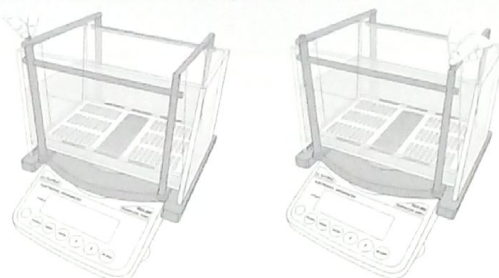

- ⑥ Attach the Lid and screw remaining two positions of the back.  
It has finished setting. Please confirm that the AC adapter type is correct for your local voltage and receptacle type.

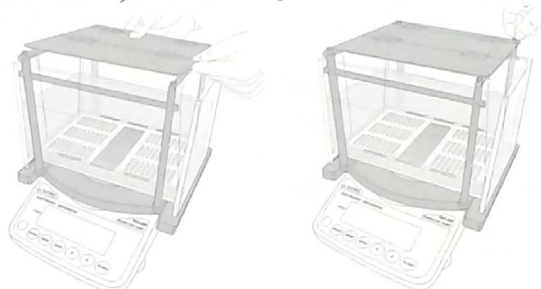



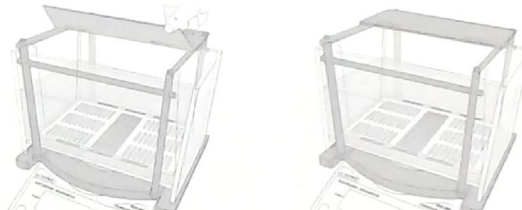

- ⑦ Fold the Lid in half size and no need to open-close the Lid every time.

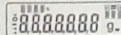

- ✓ MDS-300 is the precision instrument. Make sure that use the Airtight Wind Shield for accurate measurement.
- ✓ MDS-3000 does not contain the Airtight Wind Shield. Airflow such as the air conditioner may interfere with the accurate measurement. If you measure in such a circumstance, we recommend purchasing out the optional Airtight Wind Shield for MDS-3000.

## WARMING UP

1. This instrument is an electronic device. At the first time, it takes about 3 minutes for an electric circuit to become stable after plugged in. Plug in an AC adapter and turn on the power and warm up the machine at least 3 minutes.
2. When  does not turn to be or  the display does not get stable, zero point is out of position. Press  key to return the display to . If it does not work, proceed calibration.
3. Once this procedure is completed, the electricity remains stable in the power distribution as long as the AC adapter is being plugged in even if power is turned off.

## CALIBRATION

### ■ Necessity of calibration (adjustment of balance)

High precision electronic balance is equipped with the Electronic Densimeter: MDS-300, MDS-3000 and it calculates the specific gravity of a sample based on the weight.

Accurate results come from measuring the gravity accurately. As a characteristic of the balance, the gravity differs from place to place. Calibrate the unit on the following occasions.

- ① When the unit is installed for the first time.
- ② When the unit is transferred.
- ③ When the surroundings are changed.
- ④ In regular adjustment (Once per a week or everyday as a need arises).

A calibration weight is necessary for calibration. 200g calibration weight is contained to MDS-300. 2kg calibration weight for MDS-3000 is an option. We recommend purchasing it.



## HOW TO CALIBRATE

### MDS-300

- ① Turn the display on. Hold down **(B)** key for about 5 seconds.

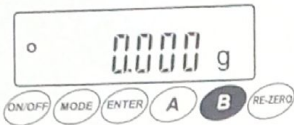

- ② Hold off **(B)** key, when [CAL out] turns to be [CAL 0].

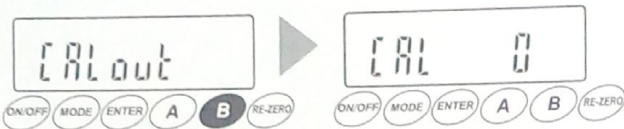

- ③ Press **(ENTER)** key, and the display turns from [CAL 0] to 200.

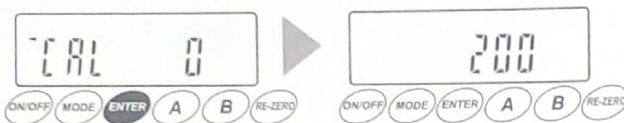

- ④ Place the 200g calibration weight on the center of the Sensor gently. And press **(ENTER)** key.



- ⑤ 200 appears and a few seconds later, [End] will be displayed. Then remove the calibration weight.



- ⑥ Display returns to 0.0000 g which means the calibration is completed. Place the calibration weight on the Sensor, and confirm that the value display is within  $\pm 1$  digits of the specified value.

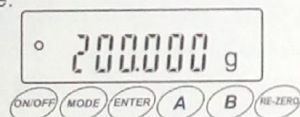

If it is not within the range of  $\pm 0.001$ g, check ambient condition such as draft, vibration and setting of all parts. Then repeat calibration again.

### ※ ERROR INDICATION

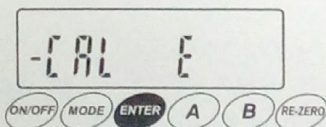
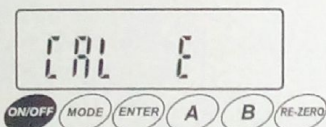

In case the display is shown as left during the calibration, it indicates error.

Press **(ON/OFF)** key to return to 0, and start from the Step ① again.

Please make sure the following matters when the error indication still appears.

- ① Sensor, Water Tank, Holder, and Support and all parts are set properly.
- ② The correct 200g or 2kg calibration weight is used.
- ③ 200 or 2000 is displayed during the calibration.
- ④ Installed location is stable without vibration and air current.

If there is no problem with above, there may be some defect or failure in the instrument. Please inform us or our agents.

### MDS-3000

- ① Turn the display on. Hold down **(B)** key for about 5 seconds.

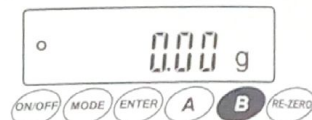

- ② Hold off **(B)** key, when [CAL out] turns to be [CAL 0].

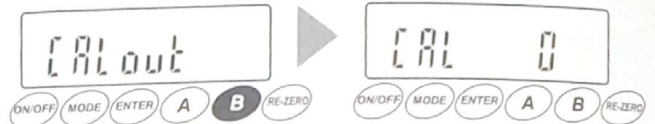

- ③ Press **(ENTER)** key, and the display turns from [CAL 0] to 2000.

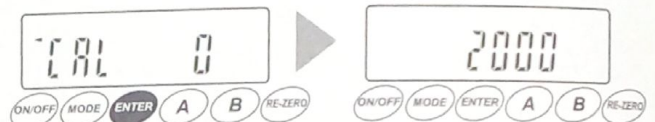

- ④ Place the 2kg calibration weight on the center of the Sensor gently. And press **(ENTER)** key.

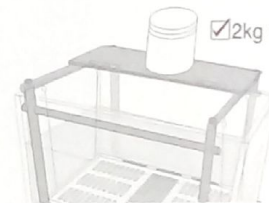

2kg Calibration weight is an option.

- ⑤ 2000 appears and a few seconds later, [End] will be displayed. Then remove the calibration weight.



- ⑥ Display returns to 0.000 g which means the calibration is completed. Place the calibration weight on the Sensor, and confirm that the value display is within  $\pm 1$  digits of the specified value.



If it is not within the range of  $\pm 0.01$ g, check ambient condition such as draft, vibration and setting of all parts. Then repeat calibration again.



# INITIAL SETTING

Change the Initial Setting before measuring in any of the following cases.

- ① When changing the measuring time
- ② When changing the minimum display digit number
- ③ When changing the Measuring Mode (Solid, Liquid and Powder)
- ④ When selecting Auto-weighing-enter function for SOLID DENSITY MODE
- ⑤ When using the liquid other than water as solution
- ⑥ When selecting other functions
- ⑦ When connecting to printers or computers

**PROCEDURE OF INITIAL SETTINGS** Refer to INITIAL SETTING LIST P16, select a value.

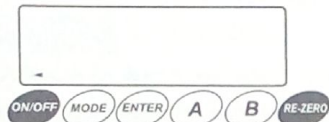

- ① Turn the display off.
- ② Hold down **RE-ZERO** key, and press **ON/OFF** key.

The first item, **C-1 A-t 0** is displayed.

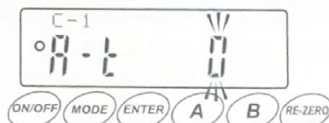

- ③ Refer to INITIAL SETTING LIST, select PAGE, CODE and VALUE by the following keys.
  - a. **C-1** means the PAGE. Press **MODE** key to change.
  - b. **A-t** means the CODE. Press **B** key to change.
  - c. **0** means the VALUE. Press **A** key to change.

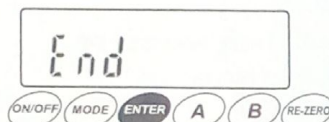

- ④ Press **ENTER** key to confirm the setting.  
Display shows **End** to zero display.

# HOW TO SET UP OTHERS

## 1. COMPENSATE WATER TEMPERATURE

By using water as solution of measurement, this instrument can measure the specific gravity of a sample against the specific gravity of water. As the specific gravity of water changes a little depending on the water temperature, so that the specific gravity of a sample changes accordingly. It is necessary to compensate water temperature based on the specific gravity: 1.000 of 4 °C water. The specific gravity of water being present in memory at every 0 to 99°C Celsius in advance, it is possible to compensate the specific gravity of a sample by setting water temperature.

✓ Refer to the next page P6 MEMORIZED DENSITY OF WATER

### SETTING PROCEDURE

- ① Measure water temperature by using the Thermometer.
- ② Turn on the power. Hold down **ENTER** key for about 5 seconds.
- ③ The present set water temperature blinks on the display. At the factory, both actual water temperature (left side) and the compensated water temperature (right side) have set 15°C.
- ④ Input the measured actual water temperature and the compensated water temperature with following procedure.
  - Press **A** key to plus 1.
  - Press **B** key to minus 1.
  - Press **MODE** key to move to right and left.

After setting, press **ENTER** key to memorize it. The display returns to zero.

The compensation setting of water temperature is completed.

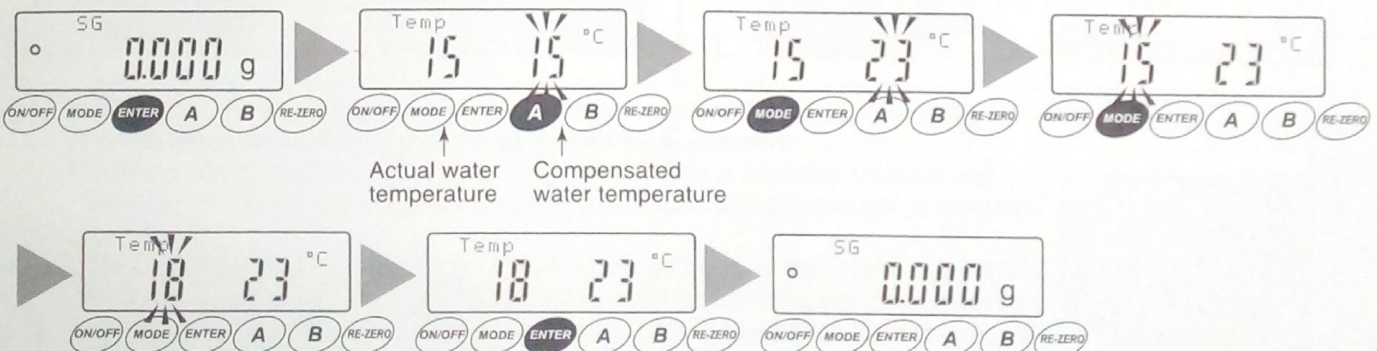



## 2. INPUT THE SPECIFIC GRAVITY OF SOLUTION

The solution other than water can be applied to this instrument at SOLID DENSITY MODE.

The result measured in the solution can be compensated for the result in water by inputting specific gravity of solution in advance. This works well for the following cases.

- ① Sample has too many bubbles when measured in water (Pellet, Powder, Sponge)
  - ② Sample is so decorative that water does not get in detail part of sample easy (Fiber and so on)
  - ③ Sample repels water (Film and so on)
- MDS-300: The Water Tank is made from Styrene resin and the Sensor and the Support are made from ABS resin.  
Do not use such a solution as to corrode them.
  - MDS-3000: The Water Tank made from PET resin, and the Measuring tray unit made from stainless.  
Do not use such a solution as to corrode them.
  - Ethanol (Specific gravity: about 0.798) is suitable for solution as well as water.  
It is inflammable, so handle with extra care.

### SETTING PROCEDURE

- ① Select the Initial Setting for setting the specific gravity of solution. Change the Initial Setting C-1, Lqd 0  $\Rightarrow$  1.
- ② Turn on the power. Hold down **ENTER** key for about 5 seconds.  
Present set value appears on the display (factory setting 1.000). The numeric leftmost blinks, and can be changed the value and set the specific gravity of the solution with following key operation below.  
Press **A** key to plus 1.  
Press **B** key to minus 1.  
Press **MODE** key to move the cursor to the next digit.
- ③ After setting, press **ENTER** key to memorize it. The display returns to zero.  
Setting the specific gravity of solution is completed.
- When using water as solution again, the above setting must be returned, the Initial Setting C-1, Lqd 1  $\Rightarrow$  0.

### MEMORIZED DENSITY OF WATER

TEMPERATURE (°C)	0	1	2	3	4	5	6	7	8	9
0	0.99984	0.99990	0.99994	0.99996	0.99997	0.99996	0.99994	0.99990	0.99985	0.99978
10	99970	99961	99949	99938	99924	99910	99894	99877	99860	99841
20	99820	99799	99777	99754	99730	99704	99678	99651	99623	99594
30	99565	99534	99503	99470	99437	99403	99368	99333	99297	99259
40	99222	99183	99144	99104	99063	99021	98979	98936	98893	98849
50	98804	98758	98712	98665	98618	98570	98521	98471	98422	98371
60	98320	98268	98216	98163	98110	98055	98001	97946	97890	97834
70	97777	97720	97662	97603	97544	97485	97425	97364	97303	97242
80	97180	97117	97054	96991	96927	96862	96797	96731	96665	96600
90	96532	96465	96397	96328	96259	96190	96120	96050	95979	95906



# SOLID DENSITY MODE

Turn on the power and check the display appeared SG (SOLID DENSITY MODE) on upper left and value zero.

→ appears on the display (MDS-3000: )

When does not appear on the display, press key to return zero.



## 1. STANDARD MEASUREMENT

Refer to NECESSARY WEIGHT AGAINST DENSITY (P14).

### MDS-300

1) Place the sample on the Sensor gently  
Weight will be displayed



2) Press key after the stable mark " " appears  
It memorized the aerial gravity of a sample, then "▼" appears right of the "g" display

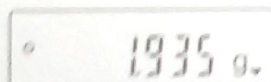

3) Hold the sample by using Tweezers and place it on the central part of the measuring tray in water gently



### MDS-3000

1) Place the sample on the Sensor gently  
Weight will be displayed

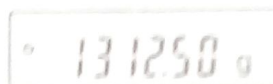

2) Press key after the stable mark " " appears  
It memorized the aerial gravity of a sample, then "▼" appears right of the "g" display

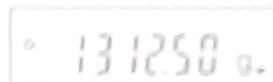

3) Hold the sample by using Tweezers and place it on the central part of the measuring tray in water gently



In doing so, remove bubbles sticking on the sample by shaking it slightly in water.  
The bubbles may interfere with the accurate measurement.

✓ In case the bubbles cannot be removed, pour some Ethanol in any other container and wash the sample with the Ethanol before sinking it in water. Most bubbles can be removed by this way.

✓ The sample has to be on measuring tray in water without touching Water Tank or out of tray.

✓ In case the sample is thin such as wire, sink the petri dish in measuring tray in water and zero the display before measurement. Then, the thin sample will not drop off from the measuring tray.



④ Place a sample on the measuring tray in water to measure the underwater gravity. Press **ENTER** key after the stable mark "○" appears. It takes the average of underwater gravity.

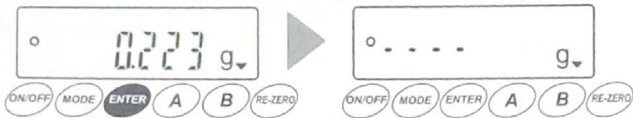

④ Place a sample on the measuring tray in water to measure the underwater gravity. Press **ENTER** key after the stable mark "○" appears. It takes the average of underwater gravity.

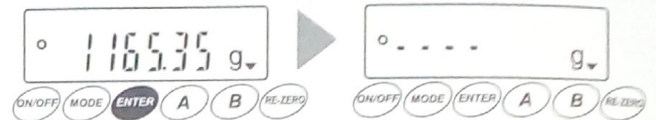

✓ When "E" shows on display, confirm stable mark "○" and press **ENTER** key again.

⑤ Measurement results are displayed. When pressing **A** key for a second, the display turns to the followings.

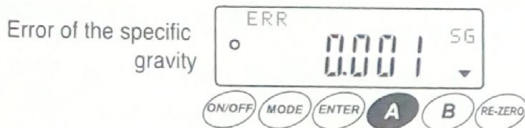
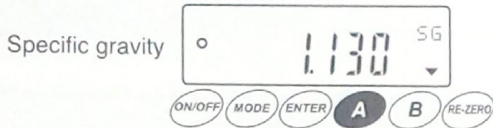

✓ Error of the specific gravity means that the digit value have error.



⑤ Measurement results are displayed. When pressing **A** key for a second, the display turns to the followings.

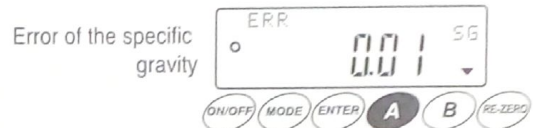
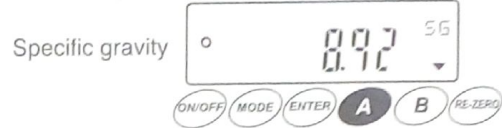

✓ Error of the specific gravity means that the digit value have error.

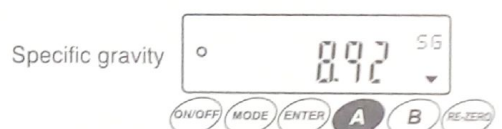

### TO FINISH MEASUREMENT AND TO CONTINUE MEASUREMENT

Take a sample out by using the Tweezers. Press **ENTER** key to return to zero.

When continuing measurement, make sure the display is zero and start from the Step ①.

✓ This instrument is an electric device. It may cause failure when the water is spilled on machine body.

- Do not spill water on the unit or spare parts.
- Do not pinch a sample inside the Water Tank with your fingers to prevent overflow.

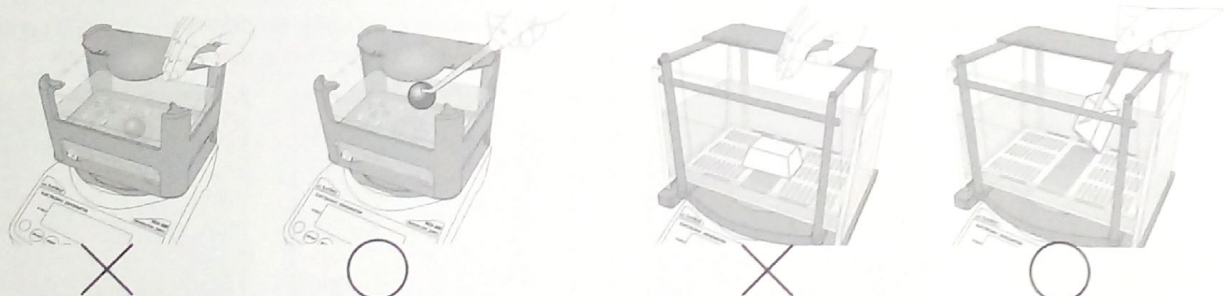

c) When measuring the same sample again, dry it well. It may not get a proper result if the sample is semidry.

### ◆ CONVENIENT FUNCTION

a) When procedure ②, and like to go back procedure ①, press **B** key for 5 seconds.

By pressing the **B** key for 5 seconds, it goes one step back procedure.

b) When procedure ⑤, and like to go back procedure ④, press **B** key for 5 seconds.

c) Auto-weighing-enter function (Initial Setting C-1, At-E 0 ⇒ 1), the machine starts taking the average weight in water automatically when it becomes stable without pressing **ENTER** key.

This is the Auto-weighing-enter function. Do not have to press the key, so that the measurement is high precision without key pressing vibration. However, when the display once appears E, press **ENTER** key after checking the stable mark "○".



## 2. FLOATING SAMPLE MEASUREMENT

By using this method, it's possible to test various floating samples such as Urethane, Sponge, Film, Wood and so on. The sample which tends to attach bubbles like Film can be measured more speedy by using ethanol which has less surface tension than water.

✓ Refer to P6 HOW TO SET UP OTHERS - 2. INPUT THE SPECIFIC GRAVITY OF SOLUTION.



✓ Illustration with MDS-900  
(Procedure with MDS-3000 is the same)

- 1) Place the Stainless Angle onto the Measuring Tray in water.  
✓ The Stainless Angle should be entirely under the water.



- 2) After the weight of the Stainless Angle appears, press the **RE-ZERO** key to return to zero.

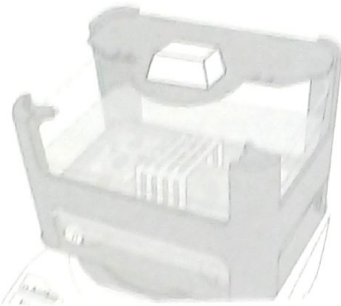

- 3) Measure the aerial gravity of the sample same as Standard Measurement of Solid P7-2).

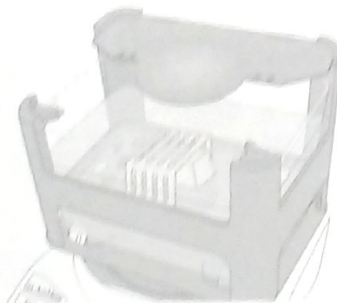
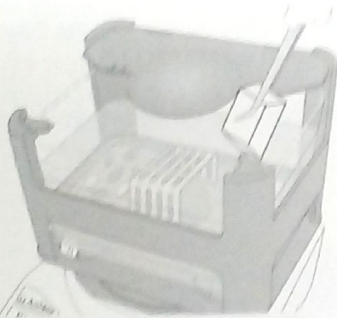

- 4) After memorized the aerial gravity, place a sample under the Stainless Angle.  
At this time, minus indication will be displayed by negative buoyancy. Press the **ENTER** key the same as Standard Measurement P7-4).  
The display shows its density less than 1.000.

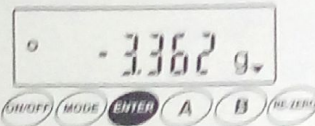

## 3. ABSORBENT SAMPLE MEASUREMENT

By using this method, it's possible to test various absorbent samples of Fiber, Rubber, Sponge, Ceramic and so on. Before measurement, change the Initial Setting C-2, DISP 0 ⇒ 1 (Renewal frequency of density). So that measuring results are renewed every second and can be measured the successive variation of the specific gravity.

- ✓ Refer to P5 INITIAL SETTING and P16 INITIAL SETTING LIST.
- ✓ It's necessary to control by a computer or a printer connected for measuring time and interval.  
It's possible to set interval of print by optional printer (AD-8121B)
- ✓ If absorbent by water is not enough, it needs to change solution.

## 4. PELLET AND POWDER MEASUREMENT

By using this method, it's possible to test Pellet (grains) and Powder.

Illustration with MDS-300  
(Procedure with MDS-3000 is the same)

### PREPARATION

- ① Change the solution from water to such as ethanol which has less surface tension than water. At following PROCEDURE ①, pour the solution until a Petri Dish on the Measuring Tray sinks slightly (Entire Petri Dish is under solution).  
It could cause inaccurate readings by too much solution.  
Do not use such solution as to erode the Water Tank.
- ② Set the specific gravity of the solution.  
Refer to P6 INPUT THE SPECIFIC GRAVITY OF SOLUTION.
- ③ Prepare a Petri Dish (Φ50~Φ70) and a medicine paper.
- ④ Prepare necessary weight of sample (Pellet or Powder)  
Refer to P14 NECESSARY WEIGHT AGAINST DENSITY.

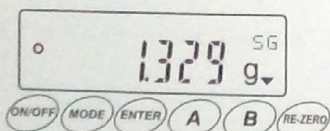
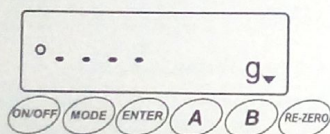
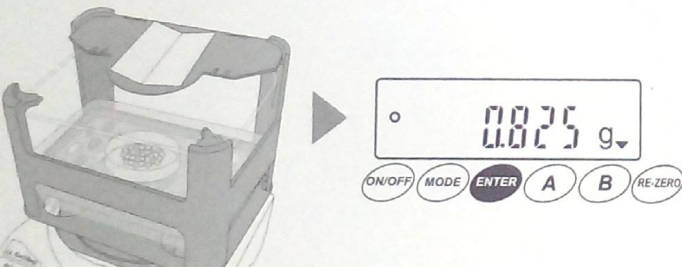
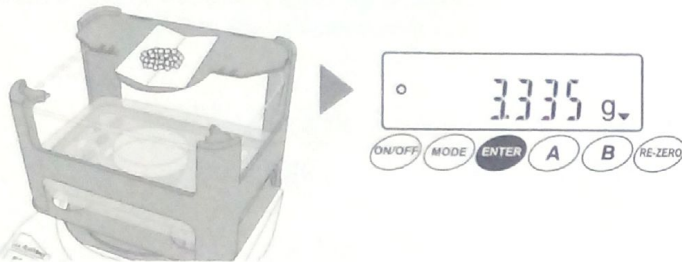
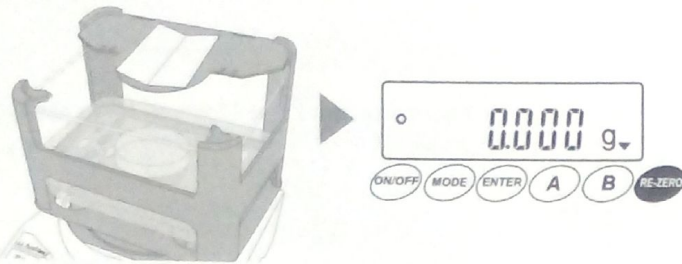

### PROCEDURE

- ① From zero display, place a Petri Dish on the center of Measuring Tray in water and medicine paper on the Lid of Sensor.  
Press **RE-ZERO** key to make the display zero.
- ② Put the sample gently on the medicine paper on the Lid of Sensor. After the aerial gravity of the sample will be displayed, press **ENTER** key to memorize it.  
Make sure not to spill the sample.
- ③ Pick up carefully the medicine paper not to spill the sample. Pour gently only the sample into the Petri Dish on the Measuring Tray in water.  
Make sure all sample are on Petri Dish.  
Any amount of sample should not be out, float or swim.
- ④ Put the empty paper of powder medicine onto the Lid as shown left. Press **ENTER** key after the weight of the sample in the solution is displayed.
- ⑤ The specific gravity of the sample will be displayed, and the measurement is completed. This result is calculated as the value in water.  
When continuing measurement, start from Step ① after taking out the Petri Dish including the sample.



# LIQUID DENSITY MODE

This machine has software which can calculate density by following two ways.  
To measure the liquid density, optional Liquid Density Kit is necessary.

- ① Room temperature liquid density
- ② Optional compensate temperature liquid density by setting the coefficient rate of the liquid by temperature change
- ✓ High viscosity liquid density can not be measured.

**LIQUID DENSITY KIT & COMPOSITION** The following Kit is for MDS-300. Please contact us about the Kit for MDS-3000.



HANGER



STANDARD GLASS  
SAMPLE (2 PCS.)



HOOK  
(2 PCS.)



50cc BEAKER  
(2 PCS.)

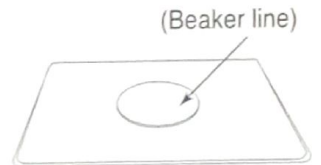

BEAKER STAGE

## 1. ROOM TEMPERATURE LIQUID DENSITY

✓ Illustration with MDS-300

### PREPARATION 1

Memorize the aerial gravity and the density of a Standard Glass Sample.

There are **A** and **B** fields of software space to be memorized for 2 of each Standard Glass Samples.



- ① Measure the Standard Glass Sample with the same procedure of Standard Measurement of Solid Density P7.

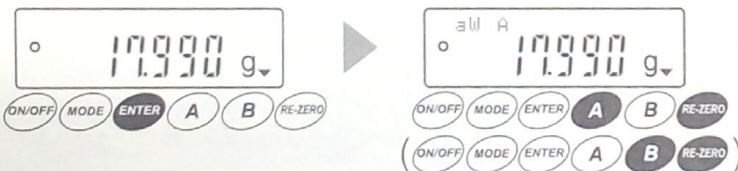

- ② At the Step ② of Standard Measurement P7. After the aerial gravity is displayed, hold down **RE-ZERO** key and press **A** key. Then the aerial gravity of the Standard Glass Sample is memorized in Memory **A**. **aW A** appears upper left on the display.

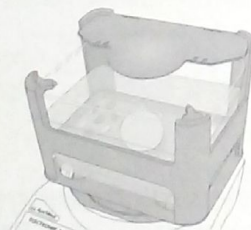

- ③ Proceed the Step ③④ and Step ⑤. After the density is displayed, hold down **RE-ZERO** key and press **A** key. Then the density of the Standard Glass Sample is memorized in Memory **A**. **d A** appears upper left on the display.

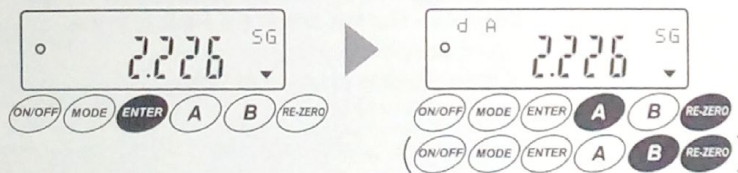

- ✓ To memorize in Memory **B**, hold down **RE-ZERO** key and press **B** key at above steps.

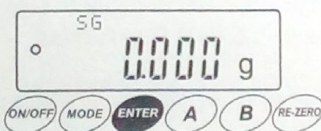

- ④ To finish, press **ENTER** key to return to zero.

**PREPARATION 2**

Replace the Sensor to the Liquid Density Kit.



Turn off the power.



Put off the Sensor and the Water Tank.  
(\*Be careful not to spill the water.)

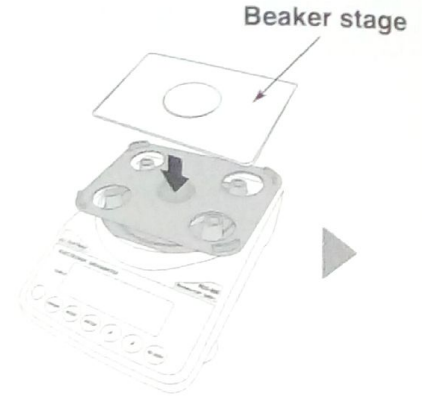

Attach the Beaker Stage on the Water Tank Holder correctly.



Put the Hanger along the side-rail on the Support.



Turn on the power and make sure the display is zero.  
Setting is completed.

**PREPARATION 3**

Select the Liquid Density Mode ON with the Initial Setting P5.

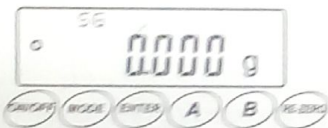

① Change the Initial Setting C-2, LSG 0 ⇒ 1.  
(Liquid Density Mode ON)



② Turn on the power and make sure the display is zero. Hold down (MODE) key for 5 sec.  $\overline{\text{0.0000 g}}$  is displayed.  
Memory (A) shows right on display, which means memorized (A) Standard Glass Sample can be used.



☑ When use memory (B), hold down (MODE) key and press (B) key to change to (B) from (A).

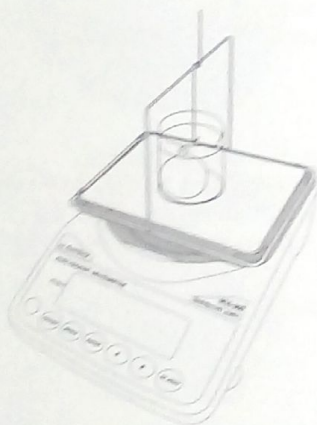

③ Pour the liquid sample and (A) Standard Glass Sample into a 50cc Beaker. Set the Beaker on the Beaker Stage.  
Suspend the Hook from the center of the Hanger. Make sure that the end of the Hook is in the Liquid sample.  
☑ It needs 50cc of Liquid sample.

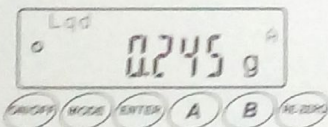

④ The weight of the Hook is displayed.  
Press (RE-ZERO) key to return to zero.  
The preparation is completed.





## MEASUREMENT PROCEDURE

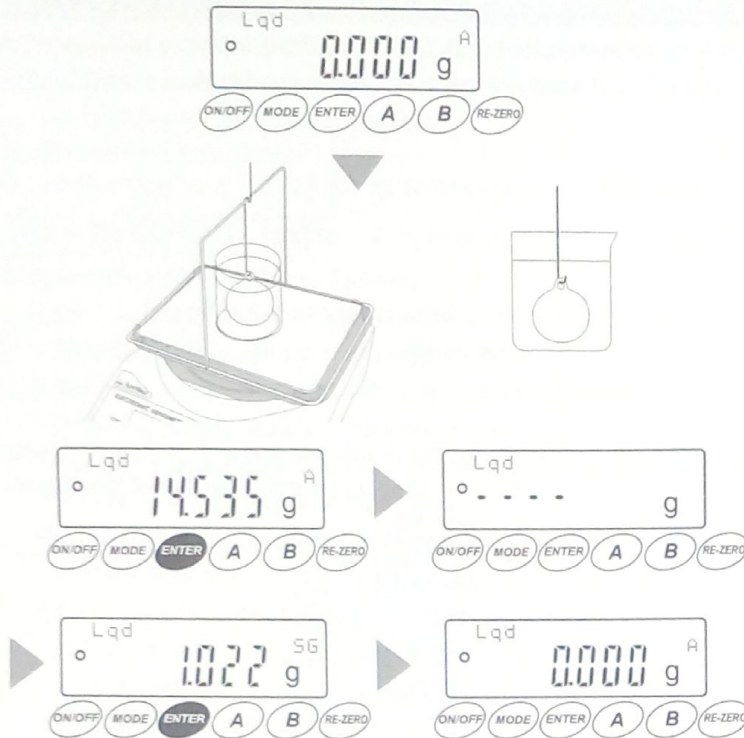

- Make sure the display is zero, then hang the (A) Standard Glass Sample by the Hook and suspend it on Hanger.  
The weight of the (A) Standard Glass Sample in the liquid is displayed.

Make sure that the Standard Glass Sample is completely in the liquid sample without touching the Beaker.

- Press **ENTER** key after the stable mark "○" appears.  
The machine calculates the density of liquid sample base on the memorized weight and density of the Standard Glass Sample.

- The liquid of density is displayed.

Press **ENTER** key to finish.

Take out the Hook and the Standard Glass Sample from the liquid sample.

- To continue measurement, prepare another Beaker and start from PREPARATION 3.  
 When using the same Standard Glass Sample, wash and dry enough before measurement.

## 2. OPTIONAL COMPENSATE TEMPERATURE LIQUID DENSITY

Liquid density at optional compensated temperature can be measured by setting the coefficient rate of the liquid.

Setting coefficient rate of the liquid is necessary.

### PREPARATION

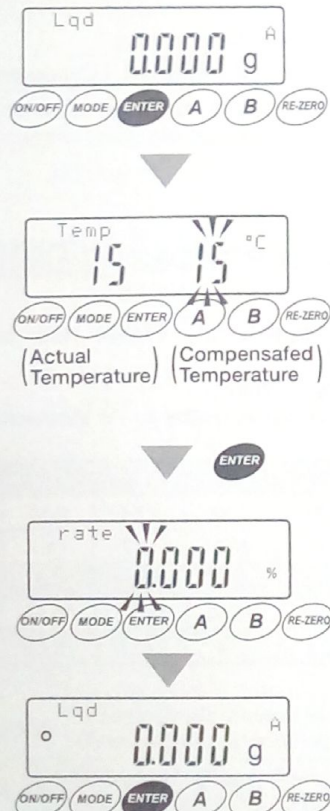

Illustration with MDS-300

- PREPARATION 1 to 2 is the same as that of ROOM TEMPERATURE LIQUID DENSITY.

- At the step of PREPARATION 3-②(P12), press **ENTER** key for 5 sec.  
Display for setting temperature comes as shown left.

- Set the actual liquid temperature on the left and compensated liquid temperature on the right.

Press **A** key to plus 1.

Press **B** key to minus 1.

Press **MODE** key to move to the next digit.

Press **ENTER** key to confirm.

- Then follow to set the liquid coefficient rate as shown left.

- Press **ENTER** key to confirm and return to PREPARATION 3-② (P12).

- Continue to PREPARATION 3-③④ and MEASUREMENT.

The measurement procedure is same as the above of this page.

# COMPARATOR FUNCTION

This is the function that can judge measuring result compared with preset standard values, between the higher limit and the lower limit. **HI**, **OK** and **LO** will be displayed on the upper right side as well as the measuring result.

## SETTING PROCEDURE

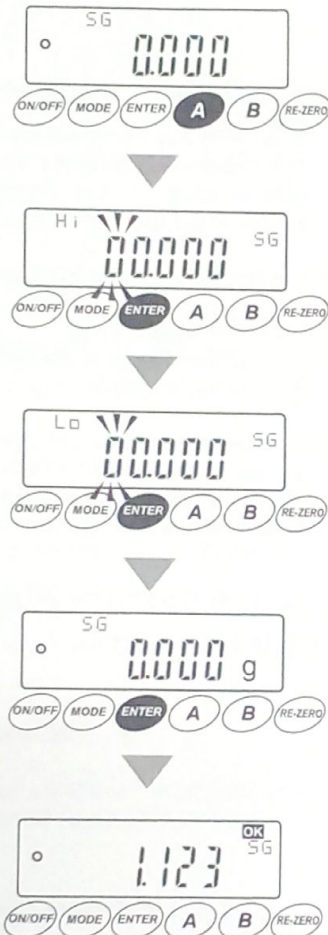

① Select the Initial Setting **C-2, CP-0** ⇒ 1  
(Comparator ON).

② Turn on the power and press **A** key for 5 sec.  
**Hi** or **Lo** appears on the upper left of the display as shown left.

By followings, change the blinking number to set the limits of the density.

Press **A** key to plus 1.

Press **B** key to minus 1.

Press **MODE** key to move to the next digit.

Press **ENTER** key to confirm, then follow to **Lo**.

③ After setting, press **ENTER** key to confirm.

The setting will be completed and return to zero.

④ Proceed measurement.

Any of **HI**, **OK** and **LO** appears on the upper right of the display at the same time as result comes up.

## NECESSARY WEIGHT AGAINST DENSITY (SOLID, POWDER)

This machine calculates the density by Archimedes' principle.

Therefore, more density sample needs more weight to have constant repeatability. Please refer to below table of Necessary weight against Density, and prepare enough weight of sample.

☑ Below table weights are necessary weight to avoid error value of last digit Density.

☑ Sample weight is less than that, value of Error of the specific gravity gets more. (Refer to P8 Measurement result)

DENSITY	0.2	0.4	0.6	0.8	1.0	1.2	1.4	1.6	1.8	2.0	2.2	2.4
MDS-300(g)	0.05	0.13	0.29	0.52	0.79	1.13	1.54	2.02	2.54	3.14	3.8	4.54
MDS-3000(g)	0.16	0.62	1.41	2.56	3.93	5.65	7.70	10.1	12.7	15.7	19.0	22.7
DENSITY	2.6	2.8	3.0	3.5	4.0	4.5	5.0	5.5	6.0	6.5	7.0	7.5
MDS-300(g)	5.32	6.18	7.08	9.64	12.58	15.92	19.66	23.60	28.32	33.98	40.00	50.40
MDS-3000(g)	26.6	30.9	35.4	48.2	62.9	79.6	98.3	118	141.6	169.9	200	252



# DATA OUTPUT

This machine can output data of the measuring results and calibration records (GLP output) using the RS232C serial interface.

1. Connecting to the Simple Printer.
2. Connecting to Original Printer.
3. Connecting to a PC (personal computer).  Prepare a straight cable (D-sub 9-pin, female connector)

## HOW TO OUTPUT DATA (1 and 2 above)

### 1. Select the Initial Setting as follows.

- ① Set Data output mode **PAGE C-3, CODE Print, VALUE 0** to 1.
  - Factory setting **VALUE 1** (Auto-print mode)
- ② Set Output data **PAGE C-3, CODE dAtA, VALUE 0** to 2
  - Factory setting **VALUE 0** (Displayed data)
- ③ Set GLP output **PAGE C-3, CODE inFo, VALUE 1** or 2 (Refer to printing sample)
  - Factory setting **VALUE 0** (Not output)
- ④ When you use Simple Printer, set **Page C-4, CODE bPS, VALUE 4** (Baud rate 9600bps)
  - And set **Page C-4, CODE btPr, VALUE 2** (Data bit, parity bit).
- ⑤ Set Data format **PAGE C-4, CODE tyPE, VALUE 0** or 1.
  - Factory setting **VALUE 0** (A&D standard format)
  - When set showing reference value on display, set **tyPE 1** (DP format). When set A&D format, reference value can not print out.
  - About others except the above, please refer to the operation manual of the printer. The setting of the printer may be required.

### 2. Contents of output data The following is an example of MDS-300

Printing sample using the Simple Printer.  All available data are printed.

AD Format	DP Format	Meaning of Printing
ST, +0030.315 ag	AW +30.315 g	ag, AW ..... Weight in air
ST, +0028.312 wg	LW +28.312 g	wg, LW ..... Weight in water
ST, +0015.122 SG	SG +15.122	SG ..... Specific gravity
ST, +0000.004 DV	DV +0.004	DV ..... Error (SG)
ST, +0002.003 CV	CV +2.003	CV ..... Volume
ST, +00000015 C	TR +15	C, TR ..... Water temperature
ST, +00000004 C	TA +4	C, TA ..... Compensated water temperature

GLP outputting sample using the Simple Printer.

AD Format	General-data Format
A Mirage MODEL MDS-300 S/N 15402832 ID 0000000  CALIBRATED(EXT.) CAL.WEIGHT +200.000 g SIGNATURE  -----	A Mirage MODEL MDS-300 S/N 15402832 ID 0000000 DATE  TIME  CALIBRATED(EXT.) CAL.WEIGHT +200.000 g SIGNATURE

### Output possible item from PC or Printer

MEASUREMENT MODE	OUTPUT POSSIBLE ITEM
SOLID DENSITY MODE	Weight in air, Weight in water, Specific gravity, Error, Volume, Actual and Compensated water temperature, Density of solution
LIQUID DENSITY MODE	Standard Glass Sample (Weight in air, Weight in water, Specific gravity), Actual and compensated liquid temperature, Liquid coefficient rate, Density of liquid







# INITIAL SETTING LIST

PAGE	CODE	VALUE	DESCRIPTION
C-1 Set up for measurement	A-t Measuring time in air	<input checked="" type="checkbox"/> 0	0 second (Memorize immediately)
		1	5 seconds
		2	10 seconds
		3	20 seconds
		4	30 seconds
	L-t Measuring time in water	0	0 second (Memorize immediately)
		<input checked="" type="checkbox"/> 1	5 seconds
		2	10 seconds
		3	20 seconds
		4	30 seconds
	Lqd Select a solution for measurement	<input checked="" type="checkbox"/> 0	Use water, set the temperature of water
		1	Use solution except water, set the specific gravity of the solution
		2	Set the weight and the density of Standard Sample (Use when the density of solution is unknown.)
	Air Air density compensation	<input checked="" type="checkbox"/> 0	No compensation
		1	Compensation (weight)
		2	Compensation (weight / specific gravity)
	Cond Response condition	0	Fast response, sensitive value
		<input checked="" type="checkbox"/> 1	Normal
		2	Slow response, stable value
	St-d Stability band width MDS-300:1 digit =0.001g MDS-3000:1 digit =0.01g	0	Stable range is ±1 digit
		1	Stable range is ±2 digits
		<input checked="" type="checkbox"/> 2	Stable range is ±3 digits
		3	Stable range is ±5 digits
		0	OFF
	trc Zero tracking	1	Normal
		<input checked="" type="checkbox"/> 2	Strong
		3	Very strong
		0	OFF
At-r Auto-rezero	<input checked="" type="checkbox"/> 0	OFF	
	1	ON	
At-E Auto-enter	<input checked="" type="checkbox"/> 0	OFF	
	1	ON	
bEEP Beep	0	No sound	
	<input checked="" type="checkbox"/> 1	Sound	
C-2 Set up for function	diSP Renewal frequency of density	<input checked="" type="checkbox"/> 0	No renewal
		1	Renewal
	EdSP Calculative tolerance display-1 ( specific gravity )	0	No display of the digit with error ( Deleted )
		<input checked="" type="checkbox"/> 1	Blink the digit with error ( Flashing )
		2	Display the digit with error ( Still )
	Err Calculative tolerance display-2 ( specific gravity )	0	No display
		<input checked="" type="checkbox"/> 1	Display
	Gr-d Digit number of weight	0	0.00g ( MDS-3000 0.0g )
		<input checked="" type="checkbox"/> 1	0.000g ( MDS-3000 0.00g )
		2	0.0000g ( MDS-3000 0.000g )
	SG-d Digit number of specific gravity	0	0.00g/cm <sup>3</sup>
		<input checked="" type="checkbox"/> 1	0.000g/cm <sup>3</sup>
2		0.0000g/cm <sup>3</sup>	

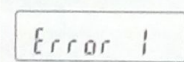

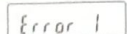
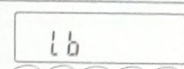
PAGE	CODE	VALUE	DESCRIPTION
C-2 Set up for function	<i>CP</i> Comparator mode	<input checked="" type="checkbox"/> 0	OFF
		1	ON
	<i>Point</i> Decimal point display	<input checked="" type="checkbox"/> 0	Dot (.)
		1	Comma (,)
	<i>LSG</i> Liquid density mode	<input checked="" type="checkbox"/> 0	OFF
		1	ON
	<i>Pro</i> Optional setting mode, number of entry	<input checked="" type="checkbox"/> 0	OFF
		1	Optional entry 1
		2	Optional entry 2
		3	Optional entry 3
		4	Optional entry 4
<i>PSG</i> Substitute density mode	<input checked="" type="checkbox"/> 0	OFF	
	1	ON	
C-3 Set up for output-1	<i>Print</i> Data output mode	0	Key mode
		<input checked="" type="checkbox"/> 1	Auto-print mode
		2	Stream mode
	<i>dAtA</i> Output data	<input checked="" type="checkbox"/> 0	Displayed data
		1	Weight in air, weight in water, displayed data
		2	All available data, weight in air, weight in water, specific gravity, etc.
	<i>S-td</i> Time / Date (Using printer AD-8121B)	<input checked="" type="checkbox"/> 0	No output
		1	Time only
		2	Date only
		3	Time and date
	<i>PUSE</i> Data output pause	<input checked="" type="checkbox"/> 0	No pause
		1	Pause (1.6 seconds)
		2	Pause (3.2 seconds)
	<i>inFo</i> GLP output	<input checked="" type="checkbox"/> 0	No output
		1	Output (AD format)
2		Output (General data format)	
C-4 Set up for output-2 (Serial)	<i>bPS</i> Baud rate	0	600bps
		1	1200bps
		<input checked="" type="checkbox"/> 2	2400bps
		3	4800bps
		4	9600bps
		5	19200bps
	<i>btPy</i> Data bit, parity bit	<input checked="" type="checkbox"/> 0	7 bits, even
		1	7 bits, odd
		2	8 bits, none
	<i>CrLF</i> Terminator	<input checked="" type="checkbox"/> 0	CR, LF
		1	CR
	<i>tyPE</i> Data format	<input checked="" type="checkbox"/> 0	AD standard format
		1	DP format
	<i>t-UP</i> Timeout	0	No limit
		<input checked="" type="checkbox"/> 1	1 second
C-6 ID number	Setting GPL output ID number		
C-9 System	<i>PF</i> Change the initial setting	<input checked="" type="checkbox"/> 0	Permitted
		1	Prohibited
		2	Initialization to factory settings

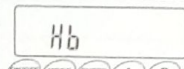
## ERROR CODE

 	<p>Stability error: The balance can not stabilize due to an environmental problem. Confirm to set up all parts correctly, and prevent vibration, drafts, temperature changes, static electricity and fields and try again. If it still shows  , inform us or our agents.</p>
 	<p>Power voltage or current is short. Confirm that ①Used equipped AC adaptor is correct for your local voltage ②Plugged receptacle outlet supply enough and stable power.</p>
 	<p>Power voltage or current is over. Confirm that ①Used equipped AC adaptor is correct for your local voltage ②Plugged receptacle outlet supply enough and stable power.</p>

## SPECIFICATION

Model	MDS-300	MDS-3000
Measuring Mode	Solid, Liquid, Powder	
Display	Specific gravity, Error, Volume, %	
Output contents	Weight in air, Weight in water, Density, Error, Volume, Water temperature, Density of solution, %	
Minimum Specific Gravity (g/cm <sup>3</sup> )	0.001	0.01
Measuring range (g)	0.001~300	0.01~3000
Measuring method	Conform to Pycnometer and Hydrostatic Method	
Standard	JIS rubber standard K6350, JIS plastic standard K7112 ASTM rubber standard D297-93-16, ASTM plastic standard D792-00-10 Other JIS, ISO and UL standard etc	
Weight (kg) / Dimensions (mm)	2.8 / (W)260 X (D)190 X (H)200	4.2 / (W)260 X (D)240 X (H)240
Possible sample size (mm)	(W)100 X (D)70 X (H)25	(W)120 X (D)100 X (H)35
Power source	AC100V ~ 240V ±10% 50 / 60 Hz	
Airtight windshield	Standard	Option
Option	Printer, Liquid density kit, ISO document, Airtight windshield (for MDS-3000), 2kg calibration weight (for MDS-3000)	

MDS-3000 can measure up to 3kg.

Requirement for bigger or customs size water tank, please contact us or our agents.

Produced by  
 ALFAMIRAGE Co., Ltd.  
 JAPAN

URL : [www.alfamirage.com](http://www.alfamirage.com)

E-mail : [sales@alfamirage.com](mailto:sales@alfamirage.com)

■1205, 5K



# Measuring capacity up to 3kg

## 重く大きな測定物に最適

### ■ 特徴

最大3kgまでの重い物を測定できる比重計です。測定物を切り離すことなく測定できるので、全体の平均的な比重を得ることができます。また測定物の大きさに合わせて比重測定容器を特注(オプション)することができます。操作は簡単、便利な自動取込機能付きです。

### Features

MDS-3000 can measure maximum capacity up to 3kg. Wide measuring capacity enables to measure the samples without cutting, and it gives the whole sample average density. Sensor & Water tank size can be customized depending on the sample size. Easy and convenient "Auto-weighing Function" is a standard feature.

### ■ 機能

#### ● 固体モード

- 最大3kgまで測定できます。今まで測定できなかった重たい物が簡単に測定できます。
- 比重と重量は最小表示0.01、さらに補助表示で0.001まで測定できます。
- 比重測定容器は、折りたたみ式になっており、測定物の大きさに合わせた使い方ができます。
- 水に浮く物やペレットも測定できます。
- 測定値を更新できるので、吸水性のある物等の比重や体積の変化率を求めることができます。
- 自動取込機能により、1回のキー操作で比重演算されるので、作業効率が大幅に改善されています。
- 独自の粉体測定モードにより、粉体の簡易測定ができます。
- 測定時間は、5種類より選択できます。
- 見やすい蛍光管表示です。

#### ● 液体モード ※液体モードにはオプションが必要です。

- 比重最小表示は0.01です。
- 液温補正、比重変化係数の設定で、温度の変化による比重値を求めることができます。
- 測定時間を選択できます。

### Functions

#### ◆ Solid Mode

- Bigger sample which could not fit in previous models, with weight up to 3kg can be measured.
- Minimum resolution of 0.01g/cm<sup>3</sup> and reference value of 0.001g/cm<sup>3</sup> can be displayed.
- Improves working efficiency and repeatability with Auto-weighing function. (Semiautomatic measurement)
- New function of powder density substituted measurement.
- Floating objects and pellets can be measured easily.

#### ◆ Liquid Mode ※Optional kit required

- Density resolution 0.01g/cm<sup>3</sup> and reference value 0.001g/cm<sup>3</sup>.
- Liquid density temperature compensation by setting liquid coefficient value depends on temperature.
- Selectable measuring time.

### ■ 仕様 / Specification

モデル	MDS-3000	Model	MDS-3000
比重最小表示(g/cm <sup>3</sup> )	0.01(0.001)	Resolution(g/cm <sup>3</sup> )	0.01(0.001)
秤量(g)	0.01(0.001)~3000	Capacity(g)	0.01(0.001)~3000
測定の種類	固体・液体・粉体	Feature	Solid, Liquid, Powder
重量(kg)	4.2	Weight(kg)	4.2
寸法(mm)	(D)260×(W)240×(H)240	Dimensions(mm)	(D)260×(W)240×(H)240
付属品	ピンセット、水温計、スチールアングル、ACアダプター、インターフェイス	Accessories	Tweezers, Thermometer, Steel Angle, AC Adapter, Interface RS232C

# MDS-3000

Resolution 0.01 (0.001) g/cm<sup>3</sup>  
Solid / Liquid / Powder (Substituted) Density

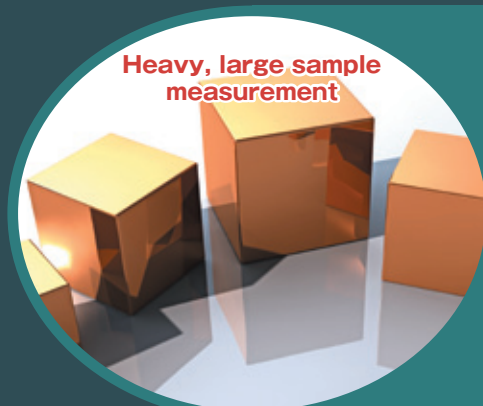
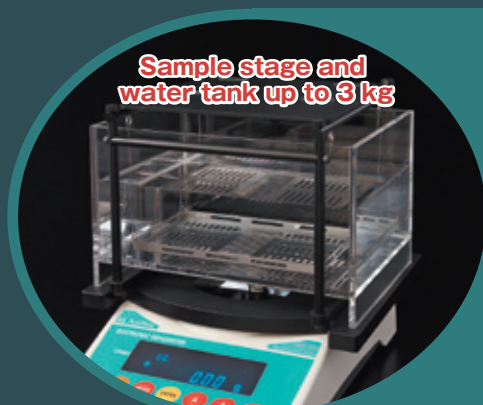

## 電子比重計 MDS-3000

固体・液体・粉体比重測定モデル  
比重最小表示0.01g/cm<sup>3</sup>

